

A human keratin 10 knockout causes recessive epidermolytic hyperkeratosis

Felix B. Müller^{1,*}, Marcel Huber^{2,†}, Tamar Kinaciyan^{3,†}, Ingrid Hausser⁴, Christina Schaffrath¹, Thomas Krieg¹, Daniel Hohl², Bernhard P. Korge¹ and Meral J. Arin¹

¹Department of Dermatology, University of Cologne, 50924 Köln, Germany, ²Department of Dermatology, CHUV Lausanne, Switzerland, ³Department of Dermatology, Medical University of Vienna, Austria and ⁴Department of Dermatology, University of Heidelberg, Germany

Received November 15, 2005; Revised and Accepted February 10, 2006

Epidermolytic hyperkeratosis (EHK) is a blistering skin disease inherited as an autosomal-dominant trait. The disease is caused by genetic defects of the epidermal keratin K1 or K10, leading to an impaired tonofilament network of differentiating epidermal cells. Here, we describe for the first time a kindred with recessive inheritance of EHK. Sequence analysis revealed a homozygous nonsense mutation of the *KRT10* gene in the affected family members, leading to a premature termination codon (*p.Q434X*), whereas the clinically unaffected consanguineous parents were both heterozygous carriers of the mutation. Semi-quantitative RT-PCR and western blot analysis demonstrated degradation of the *KRT10* transcript, resulting in complete absence of keratin K10 protein in the epidermis and cultured keratinocytes of homozygous patients. This K10 null mutation leads to a severe phenotype, clinically resembling autosomal-dominant EHK, but differing in form and distribution of keratin aggregates on ultrastructural analysis. Strong induction of the wound-healing keratins K6, K16 and K17 was found in the suprabasal epidermis, which are not able to compensate for the lack of keratin 10. We demonstrate that a recessive mutation in *KRT10* leading to a complete human K10 knockout can cause EHK. Identification of the heterogeneity of this disorder has a major impact for the accurate genetic counseling of patients and their families and also has implications for gene-therapy approaches.

INTRODUCTION

Epidermolytic hyperkeratosis (EHK; MIM 113800), also termed bullous congenital ichthyosiform erythroderma, is a keratinization disorder with an incidence of approximately one in 200 000 in the USA. The clinical phenotype of EHK is characterized by erythema (redness of the skin) and widespread formation of epidermal blisters developing with birth. Later in life, bullous erythema is replaced by progressive hyperkeratosis (thickening of the cornified layer of the epidermis). The mode of inheritance is autosomal dominant, but spontaneous mutations account for about half of the cases. In general, heterozygous missense mutations can be detected within highly conserved N-terminal and C-terminal motifs of the α -helical rod domains of keratins K1 and K10 (reviewed in 1).

Keratins are members of the intermediate filament gene family and are grouped into two classes, the acidic type I (K9-K20 and Ha1-8) and the neutral-basic type II (K1-K8 and Hb1-6) (2). Keratin intermediate filaments (KIFs) are heteropolymeric structures composed of heterodimers of a type I keratin and its specific type II keratin partner (3). In epithelial cells, keratins are the building blocks of the KIF cytoskeleton, which provides stability to epithelial cells under conditions of mechanical stress. The expression of keratin genes is highly regulated. In the epidermis, KIF assembly is a dynamic process where newly synthesized filaments are integrated into the existing network. In the basal proliferative cell compartment, keratinocytes synthesize keratins K5 and K14 and defects in either keratin are associated with the autosomal-dominant blistering disease epidermolysis bullosa simplex (EBS) (4,5). Upon commitment to terminal differentiation, K5 and K14 are

*To whom correspondence should be addressed: Tel: +49 2214785984; Fax: +49 2214785949; Email: felix.mueller@uni-koeln.de

†The authors wish it to be known that, in their opinion, the first three authors should be regarded as joint First Authors.

downregulated and the differentiation-specific keratins K1 and K10 are induced in the suprabasal layer of the epidermis.

Heterozygous point mutations of the keratin genes *KRT1* and *KRT10* in autosomal-dominant EHK result in an impaired tonofilament network of terminally differentiating keratinocytes, leading to cytolysis within the suprabasal epidermis (6–8). Ultrastructurally, this malfunction of the tonofilament network in EHK is characterized by the formation of aggregates of keratin filaments in suprabasal keratinocytes (9).

In this study, we present for the first time a kindred with a recessive form of EHK. The affected family members carry a homozygous nonsense mutation in *KRT10*, leading to complete loss of epidermal K10 expression. The phenotype is severe but not lethal. These findings are critical for the accurate diagnosis and genetic counseling of EHK patients and their families and have implications for gene-therapy approaches for keratin disorders.

RESULTS

Clinical phenotype and pedigree of the family

The three-generation pedigree shows an autosomal recessive mode of inheritance and contains two clinically affected family members in the last generation and seven genetically confirmed heterozygotes. The consanguineous parents (first degree cousins) of the affected children as well as the other heterozygous family members are clinically unaffected (Fig. 1A).

Both affected siblings showed collodion skin and generalized erythroderma at birth (Fig. 1B, affected girl postpartal). Collodion skin did not reappear after the first bathing. In the first months after birth, both children developed erosions after mild mechanical trauma and progressive ichthyosis. At the time of examination, the affected siblings exhibited generalized hyperkeratosis, which was pronounced on the big joints, elbows and knee bends (Fig. 1C and E). The 8-year old boy showed a conspicuous cobblestone morphology of the hyperkeratosis in the neck area (Fig. 1D) and the 6-year old girl displayed erythema and hyperkeratosis and additionally spontaneous erosions on the back (Fig. 1F). In both children, palmoplantar sites were not affected.

Nonsense mutation in exon 6 of *KRT10*

Sequence analysis identified a homozygous base pair exchange (CAA → TAA) at base pair position 1300 in exon 6 of *KRT10* (*c.1300 C > T*) in both affected siblings. Both parents are heterozygous carriers of the mutation. A common polymorphism could be excluded by the absence of the mutation in 50 unrelated control DNA samples. The mutation results in a premature termination codon (PTC) *p.Q434X*, 25 amino acid positions prior to the end of the 2B domain of K10. Figure 2A shows the respective part of the electropherogram and Figure 2B illustrates the position of the PTC within the K10 protein.

KRT10 mRNA and K10 protein are absent in skin and organotypic cell cultures of recessive EHK patients

In semi-quantitative RT-PCR of RNA isolated from cultured keratinocytes, a *KRT10* PCR product could be detected in the

heterozygous mother after 25 PCR cycles, whereas specific signals in the affected homozygous children did not appear even at 40 cycles, indicating a massive reduction of specific *KRT10* mRNA levels in homozygotes (Fig. 3).

Immunofluorescence analysis using two specific monoclonal mouse antibodies against keratin 10 (DE-K10 and LH2) directed against the amino-terminus showed the absence of K10 protein in the epidermis of the affected family members (Fig. 4A). Western blot analysis of cytoskeletal preparations of organotypic co-cultures using the same specific mouse monoclonal antibodies showed complete absence of K10 protein in the affected patients. In the heterozygous mother, a band of the expected size of 56.5 kDa could be detected (Fig. 5).

Keratin expression in the absence of K10

When tissue samples of the affected individuals were analysed by immunohistochemistry, profound changes in the expression of epidermal keratins and terminal differentiation markers could be observed. The distribution and expression of K1 protein, the natural type II partner keratin of K10, seemed to be unaltered. The acanthotic epidermis of recessive EHK patients showed a strong and equal basal and suprabasal staining, whereas in a control individual as well as in the heterozygous mother, K14 expression was predominantly found in the basal layer and decreased suprabasally. The proliferative keratins K6, K16 and K17 were strongly and evenly expressed in all suprabasal cell layers of the patients' epidermis, whereas only minimal staining could be detected in the control. Interestingly, the sites of cytolysis showed a correlation with the maximal K6/K16 and K17 expression. Both epidermal differentiation markers filaggrin and, to a lesser extent, loricrin showed increased staining in the granular and corneal layers of the patients' epidermis (Fig. 4A). Immunohistochemical analysis of a skin biopsy from the mother showed an expression pattern identical to the control.

Ultrastructural alterations of the epidermis in recessive EHK

Histopathologic examination of skin biopsies of the affected children revealed hyperkeratosis (increased keratinization which leads to the production of a thickened stratum corneum composed of anucleate squames), acanthosis (increase in keratinocyte population of the spinous layer with thickening of the epidermis) and papillomatosis [increase in keratinocytes with formation of projections (papillae) from the surface of skin]. The suprabasal epidermal layers showed vacuolar degeneration of the keratinocytes and, within the thickened granular layer, coarse keratohyaline granules were evident (Fig. 4B).

Electron microscopy in low magnification (Fig. 6A) showed a cell morphology similar to cases of autosomal-dominant EHK. Cytolysis was found to occur within the suprabasal layers of the epidermis. The ultrastructure of basal keratinocytes did not show pathologic changes. As soon as keratinocytes entered into terminal differentiation in suprabasal epidermal layers, increasing numbers of loose and irregularly shaped electron-dense clumps occurred. These clumps are a

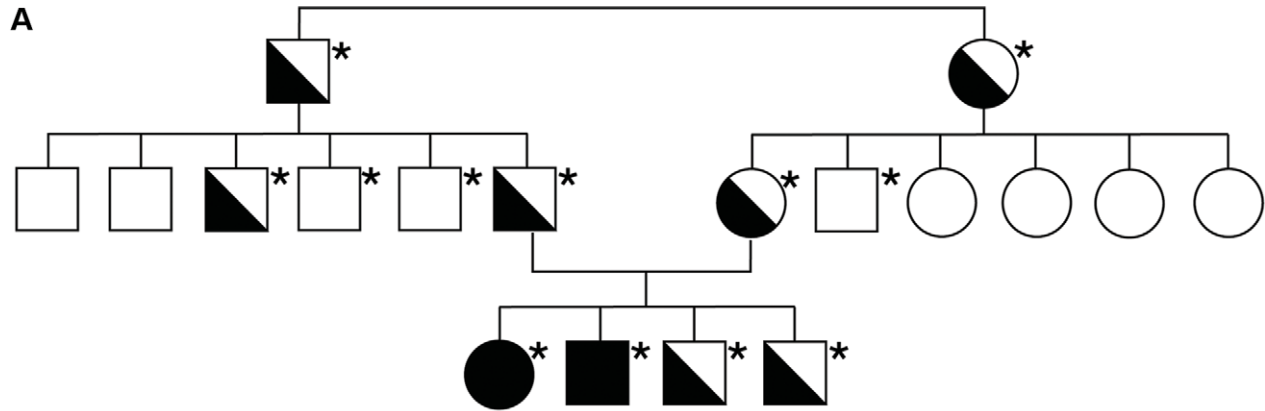

Figure 1. (A) Pedigree of the family. Genomic DNA samples were studied from the members marked with an asterisk. Carrier status is shown with respect to the mutation delineated in this study. (B–F) Clinical phenotype of the patients.

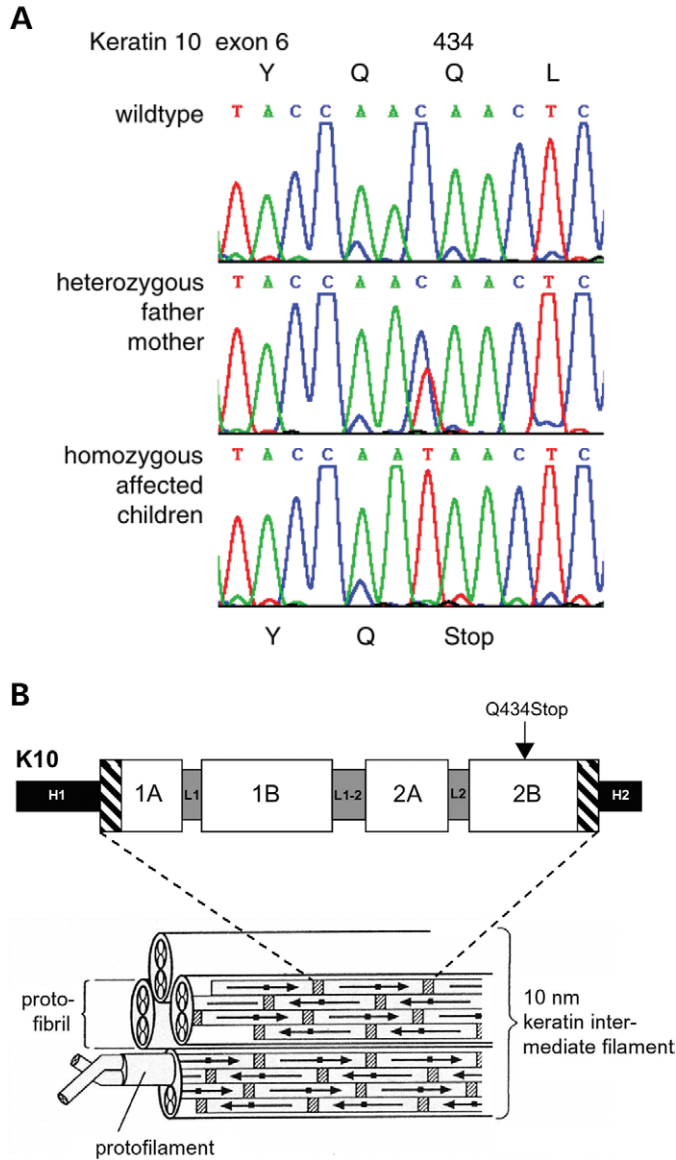

Figure 2. (A) Part of the sequence of exon 6 showing the homozygous mutation *p.Q434X* in the affected children. (B) Schematic presentation illustrating the position of the PTC within the K10 protein.

morphological hallmark of dominant EHK and correspond to aggregates of KIFs (9). Owing to the collapse of the defective cytoskeleton, the cytoplasm had a ‘vacant’, electron-lucent aspect in some areas. The nuclei tended to be located to the periphery of the cells. Keratohyalin granules were increased in number and size and had a significantly coarser structure than in normal epidermis. The structure and number of desmosomes appeared to be normal.

In higher magnifications (Fig. 6B and C), sparse keratin filaments were found within the suprabasal epidermal layers forming thin and isolated bundles. The keratin clumps were associated partially with desmosomal plaques. Perinuclear shells, as often observed in autosomal-dominant EHK patients, were absent. Noteworthy, the keratin clumps in our patients showed a nearly homogenous, amorphous structure. This is

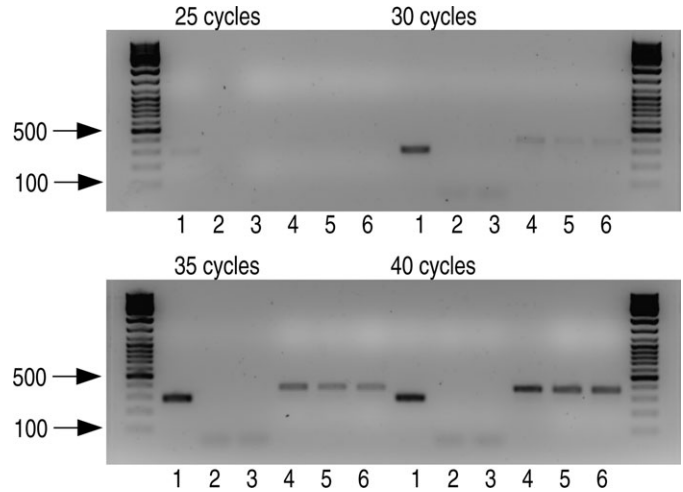

Figure 3. Semi-quantitative RT-PCR of *KRT10* mRNA in co-cultures of the affected family members (2,3,5,6) and their mother (1,4) showing complete absence of *KRT10* mRNA levels in the homozygous patients. *KRT10* PCR products were loaded in lanes 1–3 and s26 PCR products in lanes 4–6.

in contrast to the keratin clumps in autosomal-dominant EHK that regularly maintain a filamentous, thready aspect. In the heterozygous mother, no ultrastructural abnormalities of the epidermal keratinocytes could be detected in electron microscopy (data not shown).

DISCUSSION

Until now, EHK has been considered a dominantly inherited condition or due to the occurrence of dominant spontaneous mutations. In dominant keratin skin disorders, keratin missense mutations act in a dominant negative fashion, as mutated keratins perturb filament network formation after incorporation. It has been shown that even small amounts of mutated keratin can compromise the physical integrity of the entire KIF network (10). The dominant negative effect of keratin mutations is illustrated by the formation of keratin aggregates that are grouped around the nucleus, visible upon ultrastructural examination. It has been shown that these keratin clumps contain the respective keratin pairs that are specific for the state of differentiation, i.e. K5/K14 in the basal compartment in EBS and K1/K10 in the suprabasal layers of the epidermis in EHK (9).

We now report for the first time a kindred with a recessive form of EHK. The affected individuals were found to be homozygous for the nonsense mutation *p.Q434X* in the 2B domain of K10, leading to a premature stop codon, whereas the unaffected parents were heterozygous carriers of the mutation. On the basis of the position of the premature stop codon, a truncated K10 gene product of 40 kDa might be expected to be generated (Fig. 2B). As previously demonstrated in a mouse model expressing a truncated K10 peptide (11), the applied K10 antibodies LH2 and DE-K10 are directed against the amino-terminal part of the K10 protein and are able to recognize a truncated gene product comprising 230 amino-terminal residues of K10. Immunoblot analysis with the respective antibodies in the

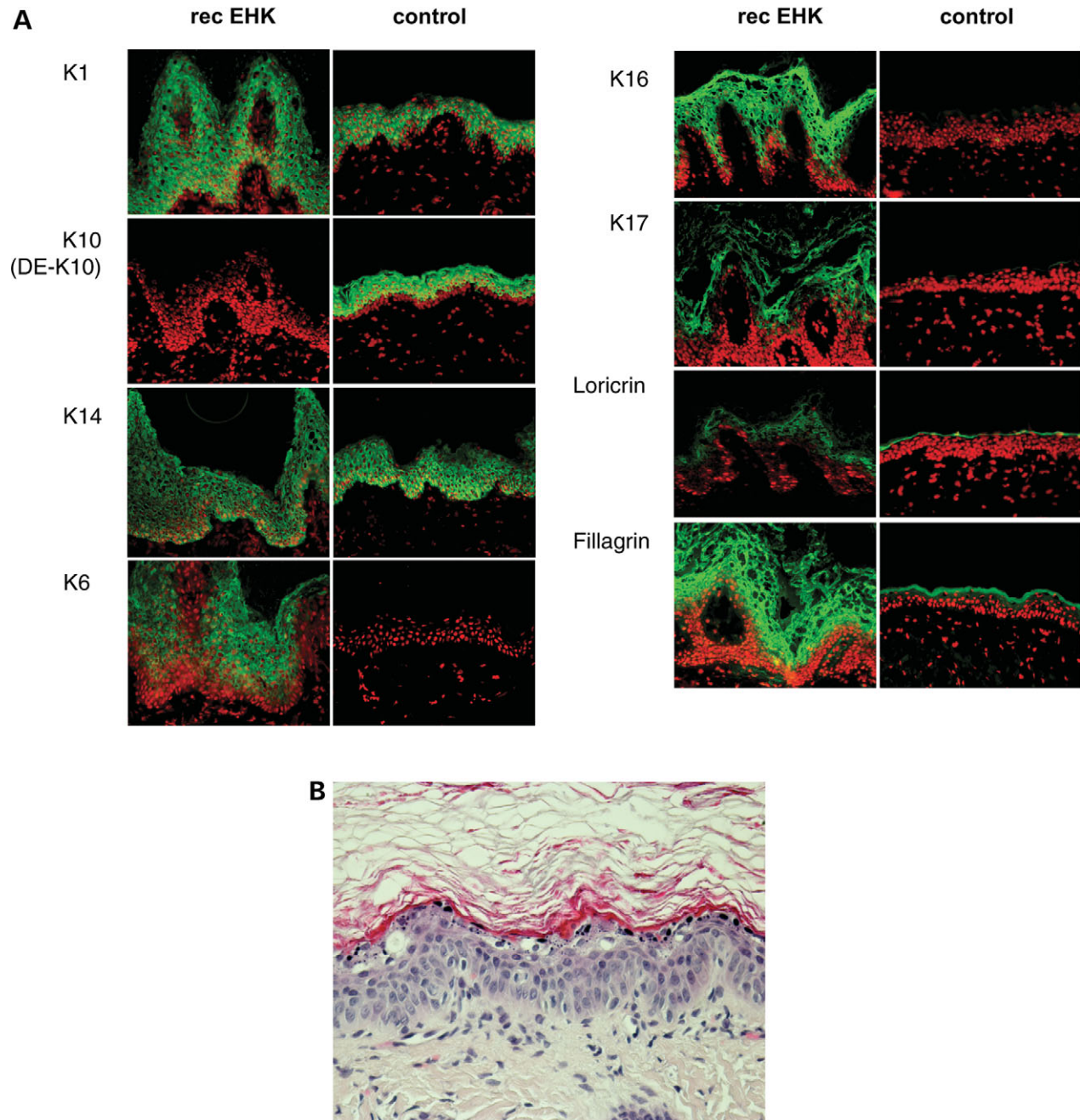

Figure 4. (A) Immunohistology of various epidermal keratins and differentiation markers showing the absence of epidermal K10 protein, persistence of K14 protein in suprabasal cell layers and strong suprabasal induction of the hyperproliferative keratins K6, K16 and K17 in the affected patient. Filaggrin and loricrin are strongly induced in the granular epidermal layers. (B) Light microscopy showing hyperkeratosis, hypergranulosis, acanthosis and vacuolar degeneration of the keratinocytes in the suprabasal layers (paraffin section, hematoxylin and eosin stain, high powered field).

affected children failed to detect K10 protein, and the existence of a truncated K10 gene product could therefore be excluded. To test whether the homozygous stop codon causes decay at the RNA level, we conducted semi-quantitative PCR on RNA isolated from cultured keratinocytes and did not detect any specific *KRT10* mRNA in the affected homozygous children. These data indicate that the mutation leads to instability and degradation of the mutant transcript and homozygous patients represent a complete human knock-

out of the *KRT10* gene. The heterozygous parents have no abnormal phenotype, indicating that the remaining healthy allele fully compensates for the loss of the mutated allele. The mutation represents to our knowledge the first nonsense mutation within a human suprabasal keratin.

Heterozygous nonsense mutations resulting in PTCs in the 2B domain of K5 or K14 have been found in autosomal-dominant EBS [*K5:p.K472X* (12); *K5:p.E477X* (13); *K14:p.E411X* (14)]. These mutations do not lead to mRNA

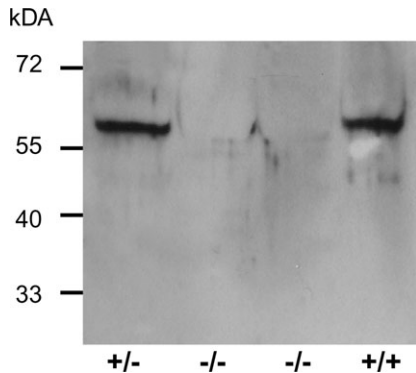

Figure 5. Western blot analysis of cytoskeletal preparations of co-cultured keratinocytes of the mother +/-, the affected children -/- and an unrelated control +/+ showing the absence of K10 protein in the affected children.

degradation and result in stable truncated gene products exerting a dominant negative effect on the keratin cytoskeleton. In contrast, it has been shown in an israelic case of EBS that the mutation *p.Q396X* in the 2B domain of K14 results in KRT14 haploinsufficiency (15). An explanation for why *K14:p.Q396X* and, the here described nonsense mutation, *K10:p.Q434X* lead to transcript decay is provided by recent studies on the mechanism of nonsense-mediated RNA decay (NMD): NMD is linked to a splicing-dependent deposition of a protein complex close to each exon–exon junction. This so-called exon-junction complex (EJC) plays a pivotal role in anchoring the NMD specific factors upf2 and upf3 to the mRNA. Translating ribosomes displace the EJCs from the open-reading frame during the ‘pioneer’ round of cytoplasmic translation which prevents NMD. If, however, the mRNA contains a PTC located more than a certain range upstream of at least one EJC, complex components downstream of the PTC will remain on the mRNA, thereby triggering NMD (reviewed in 16). It has been shown in the beta-globin gene that PTCs 50–55 nt upstream to the 3′-most exon–exon junction or downstream of this junction are not targeted by NMD (17). This distance seems to vary in different genes, as a nonsense codon as close as eight nucleotides from the last downstream intron of the TCR- β gene still triggers mRNA decay (18). All nonsense mutations in autosomal-dominant EBS reported so far are located less than 92 nt upstream of the 3′-most exon–exon junction, whereas this distance is 476 nt in *K10:p.Q434X* and 274 nt in *K14:p.Q396X*. On the basis of these data, we suggest that in keratin genes, only PTCs located at least 93 nucleotides upstream to the 3′-most intron can be targeted by NMD.

In contrast to our patients with recessive EHK, patients with recessive EBS, which is generally caused by homozygous nonsense mutations of K14, do not exhibit keratin clumping in the basal epidermal layers. In these patients, only a very sparse filament network of ‘wispy’ filaments could be demonstrated at the ultrastructural level (19). This raises the question why these two closely related disorders show such profound ultrastructural differences.

In recessive EBS, keratin K15, which is normally expressed in very low levels in basal keratinocytes, is upregulated to compensate for the absent K14. However, K5 and K15 are

apparently not able to assemble into tonofilament bundles and the presence of this very sparse keratin network is not sufficient to impart mechanical strength to these cells (19,20). The distinctive K5/K15 protofilaments were also observed in a K14 knockout mouse model (21). In the absence of K14, K15 is able to build a bona fide, but ultrastructurally distinct, network with K5. In tissues with higher levels of K15 than K14 such as neonatal esophagus, KIF networks appear unchanged as a consequence of K14 ablation. Thus, it was concluded that K5 has two natural partners, K14 and K15. However, in epidermis, the K5/K15 network is obviously not sufficient to compensate for the more robust K5/K14 network (21). In recessive EBS, upregulation of other type I keratins was not found, precluding formation of atypical heterodimers of K5 with K16 or K17.

In the human K10 knockout, ultrastructural analysis showed thin and isolated bundles of keratin filaments within the suprabasal layers. As *in vivo*, K10 (type I keratin) forms obligate heterodimers with K1 (type II keratin), it was of interest to study upregulation of alternative type I keratins in the absence of K10. The formation of keratin aggregates in the absence of mutated keratin K10 protein suggests a formation of instable atypical heterodimers between residual K1 and another type I keratin such as keratin K16 or K17, which were found to be strongly induced in addition to keratin 6 in the suprabasal layers of our patients. Generally, these ‘hyperproliferative’ keratins are not expressed in normal interfollicular epidermis and restricted to the outer root sheet of the hair follicle (22). In wound healing and hyperproliferative processes, these keratins are strongly induced. However, keratin K6/K16 heterodimers form relatively poor intermediate filaments when compared with those built up from keratins constitutively expressed in the epidermis (23,24). The amorphous structure of the keratin aggregates in recessive EHK might indicate the incapability of these atypical heterodimers to form higher order structures as keratin filaments or protofilaments. Particular qualities of this keratin pair might therefore additionally contribute to skin fragility and cytolysis in recessive EHK. This hypothesis is supported by the finding that the sites of cytolysis show a correlation with the maximal K6/16 and K17 expression in the homozygous patients (Fig. 4).

Interestingly, K10 null mice which had been generated by targeted inactivation of the keratin 10 gene show a very mild phenotype (25). The basal keratins K5, K14 and K15 persisted suprabasally and it was postulated that in this mouse model, the lack of K10 is compensated by decreased proteolysis of the basal keratins K5 and K14 and their persistence in suprabasal epidermal layers. Ultrastructurally, keratin aggregates were found and shown to consist of residual K1, which formed atypical heterodimers with K14. Despite of the complete lack of K10 protein in neonatal mice, an intact epidermis developed without signs of increased fragility or cytolysis (25,26). Persistence of K14 expression in suprabasal layers could also be demonstrated in the human K10 knockout, but obviously basal keratins are not able to compensate for the loss of keratin K10 as in the K10 null mouse model.

In a recent description of an autosomal recessive epidermolytic ichthyosis in an extended pedigree of Norfolk terrier dogs,

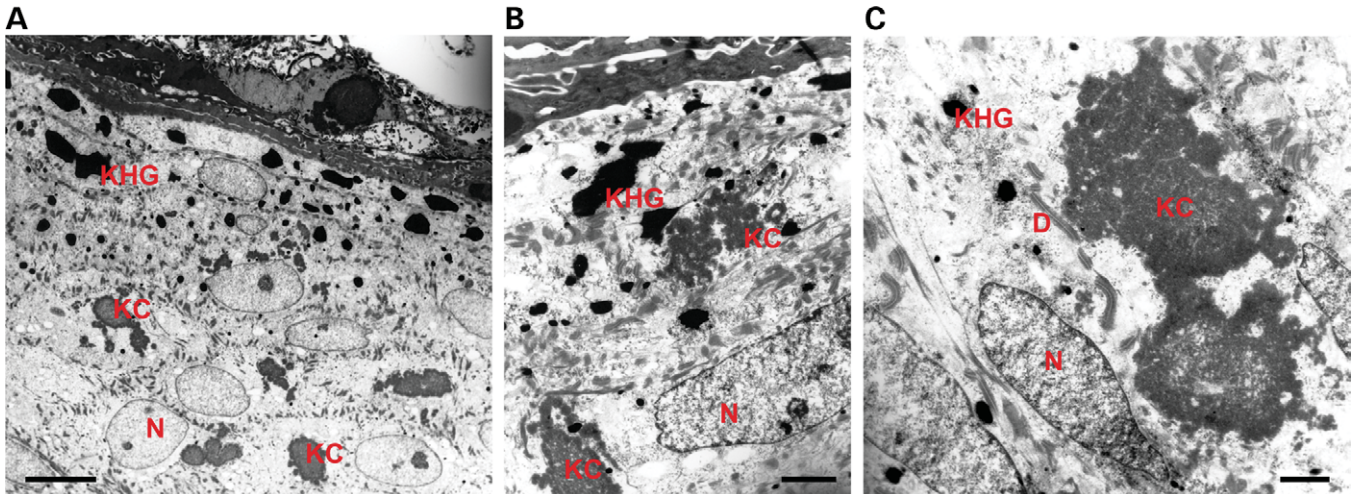

Figure 6. Ultrastructural analysis of skin biopsies of the affected children (A–C) showing coarse keratohyaline granules (KHG) and keratin clumping (KC) in suprabasal keratinocytes. N, nucleus; D, desmosome. Bars: (A) 10 μm ; (B and C) 20 μm .

which is caused by a splice-site mutation in the canine *KRT10* gene, keratin clumps were also observed upon ultrastructural analysis (27). Homozygotes showed a mild phenotype after birth, whereas heterozygotes were clinically normal. As no keratin 10 protein was detected in the homozygous dogs, it is tempting to speculate that a similar pathogenetic mechanism takes place to that in the human disease. Moreover, the milder phenotype in mouse and canine when compared with human recessive EHK might be explained by additional stability against mechanical stress provided by pelage hair.

Our findings have implications for gene-therapy approaches in both dominant and recessive EHK: recessive disorders can potentially be cured by delivery of a wild-type copy of the aberrant gene. We have demonstrated in recessive EHK that the heterozygous family members maintain a normal clinical phenotype with a single copy of the *KRT10* gene. Thus, introduction of a single copy of the normal *KRT10* gene should restore a normal filament network in the homozygous affected individuals. That one wildtype copy of K10 is sufficient to maintain normal KIF function was also demonstrated in a mouse model for the dominant form of EHK (28). Reduced expression of the mutant K10 allele in this mouse was associated with a very mild phenotype and maintenance of normal KIF function. In line with these data, this study provides further evidence that in keratin disorders, improvement of the phenotype may be achieved by partial suppression of the mutant allele or overexpression of the normal allele. Gene-therapy approaches altering the ratio of wild-type to mutant protein should therefore be sufficient to restore the epidermis to normal function.

Identification of the heterogeneous mode of inheritance of EHK has a major impact for the accurate genetic counseling: so far, the risk of a second affected child in clinically unaffected parents has been regarded to be only slightly increased by the possibility of a parental mosaicism. Now, careful exploration of the family pedigree has to be performed to exclude parental consanguinity and a recessive inheritance.

MATERIALS AND METHODS

Sources of material

Skin biopsy specimens were taken by excision biopsy under local anesthesia from the affected children and their mother, with informed consent. The samples were taken from left thigh and from left hip. After excision, skin samples were subdivided for tissue culture, EM analysis and immunofluorescence analysis. Blood samples were taken from all available family members (marked by an asterisk in Fig. 1A) for extraction of DNA.

Mutation detection

Genomic DNA isolated from EDTA blood samples was used to amplify exons 1–7 of *KRT10* by PCR using exon-specific primer pairs (data not shown). Primers for amplification of exon 6 were 5'-CAT ACT CAA CTG AAC AAG GAA GTC ACT-3' and 5'-CTG TAC TCT ACC CTC TCT CCT CCC T-3'.

An aliquot of 50 μl reaction solution containing 250 ng DNA, 200 nM of each primer, 200 μM of each dNTP, 5 μl BioTherm buffer (Natutec, Frankfurt, Germany) was initially denatured at 94°C for 2 min, followed by 40 cycles of 45 s at 94°C, 45 s at 60°C and 1 min at 72°C, followed by a 7 min final extension step at 72°C. After pre-treatment, according to the manufacturer's protocol with exonuclease I (Amersham Biosciences Europe, Freiburg, Germany) and shrimp alkaline phosphatase (USB, Cleveland, OH, USA) to eliminate remaining oligonucleotides and dNTPs, the PCR products were directly sequenced on a ABI PrismTM 377 DNA Sequencer (Applied Biosystems, Foster City, CA, USA) applying the Taq FS BigDye-Terminator cycle sequencing method. The same forward primer as in PCR was used in the sequencing reaction.

Light microscopy and electron microscopy

Hematoxylin and eosin-stained paraffin sections were examined for routine light microscopy. For electron microscopy,

skin samples fixed in cacodylate-buffered 3% glutaraldehyde and postfixed in 1% OsO₄ solution, dehydrated in graded ethanol solutions and embedded in gycidether 100 (formerly Epon 812). Ultrathin sections were investigated using a Philips EM 400 electron microscope.

Immunofluorescence analysis

Immunoreactivities (IRs) against epidermal keratins and filaggrin were analysed using specific mouse-anti-human monoclonal antibodies. Antibodies against keratins K1 (LHK1), K6 (LHK6B), K10 (LH2), K14 (LL001), K16 (LL025) and K17 (E3) were a generous gift of Irene Leigh, Department of Dermatology, Queen Mary and St Bartholomew School of Medicine, London. Another monoclonal antibody to K10 Ab-2 (DE-K10) was purchased from Dianova, Hamburg, Germany. The filaggrin antibody Ab-1 (FLG01) was purchased from Neomarkers, Westinghouse, Fremont, USA. The secondary Alexa Fluor 488 goat-anti-mouse antibody was purchased from Molecular Probes Europe, Leiden, the Netherlands. For immunofluorescence analysis of loricrin, a polyclonal rabbit-anti-mouse antibody AF62 was used (Covance, Berkeley, CA, USA). The secondary Alexa fluor 488 goat-anti-rabbit antibody was purchased from Dako (DAKO, Hamburg, Germany). Sections of 5 µm were cut on a cryostat microtome (Microm HM560) and placed on electrostatically charged slides (Superfrost plus, BDH). Frozen sections were dried and fixed in acetone for 10 min. Non-specific binding was blocked with 10% dilution of normal goat serum in PBS for 1 h. Sections were incubated with undiluted antibodies K1, K10, K14, K6, K16, K17, a 1:50 dilution of the filaggrin antibody and a 1:2500 dilution of the loricrin antibody (all in 0.2% fish skin gelatine) overnight at 4°C. Slides were washed twice in phosphate-buffered saline (PBS; pH 7.6). The secondary goat-anti-mouse antibody was applied in a dilution of 1:200 and the secondary goat-anti-rabbit antibody in dilution of 1:500 in 0.2% fish skin gelatine at room temperature for 45 min. Sections were again washed twice in PBS before counterstaining with propidium iodide 1:100 for 10 min. After a further washing step, sections were fixed with 4% formaldehyde solution for 5 min and covered with gelvatol. Immunoreactivity was visualized on a Nikon Eclipse E800 fluorescence microscope. Control sections treated without primary antibody were devoid of IR.

Organotypic co-culture

Skin specimens were obtained from the homozygous family members and their heterozygous mother. Human keratinocytes were explanted and cultured for three passages on 3T3 fibroblast feeders as described previously (29). Fibroblasts were isolated from the dermis using collagenase I and cultured in Dulbecco's modified eagle medium (DMEM) + 10% fetal calf serum (FCS). Later, keratinocytes and fibroblasts were co-cultured in Nunc cell culture inserts (Nunc, Roskilde, Denmark). Fibroblasts were embedded in 3 ml collagen lattices (rat tail collagen I, BD Biosciences, Bedford, MA, USA) at a density of 1.5×10^6 cells per ml. After culture in DMEM + 10% FCS medium for 6 days, medium was changed to a keratinocyte growth medium

containing 5% FCS and on the following day 250 000 keratinocytes were seeded onto the gel. Seven days later, the co-culture system was lifted to the air-liquid interface and cultured for additional 10 days in the presence of serum-free keratinocyte growth medium.

Semi-quantitative RT-PCR

Co-cultured cells were homogenized using a mixer mill (MM300, Retsch, Haan, Germany) and RNA was prepared using the RNeasy Total RNA Kit (Qiagen, Düsseldorf, Germany). An aliquot of 1 µg of poly(A)RNA was primed with Oligo-dT and reverse transcribed in the presence of RNAsin (Boehringer, Mannheim, Germany) using the Omni-Script RT Kit (Qiagen, Düsseldorf, Germany). A 290 bp fragment of *KRT10* cDNA was amplified using a forward primer from exon 4, 5'-CCT TCG AAA TGT GTC CAC TGG-3', and a reverse primer from exon 6, 5'-CAG GGA TTG TTT CAA GGC CA-3'. Primers were generated using Primer Express software (Applied Biosystems, Foster City, CA, USA). The reverse primer was designed to span an intron-exon boundary to prevent amplification of genomic DNA. Specific primers were used for amplification of a 374 bp fragment of ribosomal S26 cDNA (30) to normalize mRNA levels. Amplification was carried out with 1 µl of the RT product in a final volume of 50 µl for 40 cycles using the same PCR protocol as for mutation analysis. At cycles 25, 30, 35 and 40, 5 µl of the PCR product was taken out of the reaction tube. After PCR amplification, these 5 µl aliquots were subjected to electrophoresis on a 1.5% agarose gel. Ethidium bromide (0.5 µg/ml) was used to visualize the PCR fragments under ultraviolet light.

SDS-PAGE and western blot analysis

After organotypic co-culture, the epithelium was separated from the underlying collagen lattice using fine watchmaker forceps and cytoskeletal preparations were obtained as described (31). One-dimensional SDS-PAGE of keratin preparations was performed according to the method of Laemmli *et al.* (32). The proteins were electrotransferred to nitrocellulose membranes (Amersham, Hybond-ECL) according to the method of Towbin *et al.* (33). Membranes were blocked in 5% non-fat milk powder in Tris-buffered saline with 0.1% Tween-20. The primary antibody LH2 was diluted 1:100. For detection, we used a horse radish peroxidase-conjugated rabbit anti-mouse antibody 1:600 (DakoCytomation, Glostrup, Denmark).

ACKNOWLEDGEMENTS

We wish to express our sincere thanks to the family for their willing collaboration. We thank Kerstin Wodecki for excellent technical assistance. This study was supported by the Köln Fortune Program, Faculty of Medicine, University of Cologne (F.B.M.) and a network grant of the BMBF (Bundesministerium für Bildung und Forschung, Network for Ichthyoses and Related Keratinization disorders, NIRK) (F.B.M., I.H., C.S. and M.J.A.).

Conflict of Interest statement. None declared.

REFERENCES

1. Smith, F. (2003) The molecular genetics of keratin disorders. *Am. J. Clin. Dermatol.*, **4**, 347–364.
2. Moll, R., Franke, W.W., Volc-Platzer, B. and Krepler, R. (1982) Different keratin polypeptides in epidermis and other epithelia of human skin: a specific cytokeratin of molecular weight 46,000 in epithelia of the pilosebaceous tract and basal cell epitheliomas. *J. Cell Biol.*, **95**, 285–295.
3. Steinert, P.M., North, A.C. and Parry, D.A. (1994) Structural features of keratin intermediate filaments. *J. Invest. Dermatol.*, **103**, 19S–24S.
4. Coulombe, P.A., Hutton, M.E., Letai, A., Hebert, A., Paller, A.S. and Fuchs, E. (1991) Point mutations in human keratin 14 genes of epidermolysis bullosa simplex patients: genetic and functional analyses. *Cell*, **66**, 1301–1311.
5. Bonifas, J.M., Rothman, A.L. and Epstein, E.H., Jr (1991) Epidermolysis bullosa simplex: evidence in two families for keratin gene abnormalities. *Science*, **254**, 1202–1205.
6. Cheng, J., Syder, A.J., Yu, Q.C., Letai, A., Paller, A.S. and Fuchs, E. (1992) The genetic basis of epidermolytic hyperkeratosis: a disorder of differentiation-specific epidermal keratin genes. *Cell*, **70**, 811–819.
7. Chipev, C.C., Korge, B.P., Markova, N., Bale, S.J., DiGiovanna, J.J., Compton, J.G. and Steinert, P.M. (1992) A leucine–proline mutation in the H1 subdomain of keratin 1 causes epidermolytic hyperkeratosis. *Cell*, **70**, 821–828.
8. Rothnagel, J.A., Dominey, A.M., Dempsey, L.D., Longley, M.A., Greenhalgh, D.A., Gagne, T.A., Huber, M., Frenk, E., Hohl, D. and Roop, D.R. (1992) Mutations in the rod domains of keratins 1 and 10 in epidermolytic hyperkeratosis. *Science*, **257**, 1128–1130.
9. Anton-Lamprecht, I. (1994) Ultrastructural identification of basic abnormalities as clues to genetic disorders of the epidermis. *J. Invest. Dermatol.*, **103**, 6S–12S.
10. Coulombe, P.A., Chan, Y.M., Albers, K. and Fuchs, E. (1990) Deletions in epidermal keratins leading to alterations in filament organization *in vivo* and in intermediate filament assembly *in vitro*. *J. Cell Biol.*, **111**, 3049–3064.
11. Reichelt, J., Bauer, C., Porter, R., Lane, E. and Magin, V. (1997) Out of balance: consequences of a partial keratin 10 knockout. *J. Cell Sci.*, **110**, 2175–2186.
12. Livingston, R.J., Sybert, V.P., Smith, L.T., Dale, B.A., Presland, R.B. and Stephens, K. (2001) Expression of a truncated keratin 5 may contribute to severe palmar–plantar hyperkeratosis in epidermolysis bullosa simplex patients. *J. Invest. Dermatol.*, **116**, 970–974.
13. Muller, F.B., Anton-Lamprecht, I., Kuster, W. and Korge, B.P. (1999) A premature stop codon mutation in the 2B helix termination peptide of keratin 5 in a German epidermolysis bullosa simplex Dowling–Meara case. *J. Invest. Dermatol.*, **112**, 988–990.
14. Gu, L.H., Ichiki, Y., Sato, M. and Kitajima, Y. (2002) A novel nonsense mutation at E106 of the 2B rod domain of keratin 14 causes dominant epidermolysis bullosa simplex. *J. Dermatol.*, **29**, 136–145.
15. Ciubotaru, D., Bergman, R., Baty, D., Indelman, M., Pfendner, E., Petronius, D., Moualem, H., Kanaan, M., Ben Amitai, D., McLean, W.H. *et al.* (2003) Epidermolysis bullosa simplex in Israel: clinical and genetic features. *Arch. Dermatol.*, **139**, 498–505.
16. Lejeune, F. and Maquat, L.E. (2005) Mechanistic links between nonsense-mediated mRNA decay and pre-mRNA splicing in mammalian cells. *Curr. Opin. Cell Biol.*, **17**, 309–315.
17. Zhang, J., Sun, X., Qian, Y. and Maquat, L.E. (1998) Intron function in the nonsense-mediated decay of beta-globin mRNA: indications that pre-mRNA splicing in the nucleus can influence mRNA translation in the cytoplasm. *RNA*, **4**, 801–815.
18. Carter, M.S., Li, S. and Wilkinson, M.F. (1996) A splicing-dependent regulatory mechanism that detects translation signals. *EMBO J.*, **15**, 5965–5975.
19. Chan, Y., Anton-Lamprecht, I., Yu, Q.C., Jackel, A., Zabel, B., Ernst, J.P. and Fuchs, E. (1994) A human keratin 14 ‘knockout’: the absence of K14 leads to severe epidermolysis bullosa simplex and a function for an intermediate filament protein. *Genes Dev.*, **8**, 2574–2587.
20. Jonkman, M.F., Heeres, K., Pas, H.H., van Luyn, M.J., Elema, J.D., Corden, L.D., Smith, F.J., McLean, W.H., Ramaekers, F.C., Burton, M. *et al.* (1996) Effects of keratin 14 ablation on the clinical and cellular phenotype in a kindred with recessive epidermolysis bullosa simplex. *J. Invest. Dermatol.*, **107**, 764–769.
21. Lloyd, C., Yu, Q.C., Cheng, J., Turksen, K., Degenstein, L., Hutton, E. and Fuchs, E. (1995) The basal keratin network of stratified squamous epithelia: defining K15 function in the absence of K14. *J. Cell Biol.*, **129**, 1329–1344.
22. Stark, H.J., Breitreutz, D., Limat, A., Bowden, P. and Fusenig, N.E. (1987) Keratins of the human hair follicle: ‘hyperproliferative’ keratins consistently expressed in outer root sheath cells *in vivo* and *in vitro*. *Differentiation*, **35**, 236–248.
23. Paladini, R.D., Takahashi, K., Bravo, N.S. and Coulombe, P.A. (1996) Onset of re-epithelialization after skin injury correlates with a reorganization of keratin filaments in wound edge keratinocytes: defining a potential role for keratin 16. *J. Cell Biol.*, **132**, 381–397.
24. Takahashi, K., Folmer, J. and Coulombe, P.A. (1994) Increased expression of keratin 16 causes anomalies in cytoarchitecture and keratinization in transgenic mouse skin. *J. Cell Biol.*, **127**, 505–520.
25. Reichelt, J., Bussow, H., Grund, C. and Magin, T.M. (2001) Formation of a normal epidermis supported by increased stability of keratins 5 and 14 in keratin 10 null mice. *Mol. Biol. Cell*, **12**, 1557–1568.
26. Reichelt, J. and Magin, T.M. (2002) Hyperproliferation, induction of c-Myc and 14-3-3sigma, but no cell fragility in keratin-10-null mice. *J. Cell Sci.*, **115**, 2639–2650.
27. Credille, K.M., Barnhart, K.F., Minor, J.S. and Dunstan, R.W. (2005) Mild recessive epidermolytic hyperkeratosis associated with a novel keratin 10 donor splice-site mutation in a family of Norfolk terrier dogs. *Br. J. Dermatol.*, **153**, 51–58.
28. Arin, M.J., Longley, M.A., Wang, X.J. and Roop, D.R. (2001) Focal activation of a mutant allele defines the role of stem cells in mosaic skin disorders. *J. Cell Biol.*, **152**, 645–649.
29. Watt, F. (1994) Cultivation of human epidermal keratinocytes with a 3T3 feeder layer. In Celis, J.E. (ed.), *Cell Biology: A Laboratory Handbook*. Academic Press, San Diego, pp. 83–89.
30. Zigrino, P., Drescher, C. and Mauch, C. (2000) Collagen-induced proMMP-2 activation by MT1-MMP in human dermal fibroblasts and the possible role of alpha2beta1 integrins. *Eur. J. Cell Biol.*, **80**, 68–77.
31. Franke, W.W., Schiller, D.L., Moll, R., Winter, S., Schmid, E., Engelbrecht, I., Denk, H., Krepler, R. and Platzer, B. (1981) Diversity of cytokeratins. Differentiation specific expression of cytokeratin polypeptides in epithelial cells and tissues. *J. Mol. Biol.*, **153**, 933–959.
32. Laemmli, U.K. (1970) Cleavage of structural proteins during the assembly of the head of bacteriophage T4. *Nature*, **227**, 680–685.
33. Towbin, H., Staehelin, T. and Gordon, J. (1992) Electrophoretic transfer of proteins from polyacrylamide gels to nitrocellulose sheets: procedure and some applications. 1979. *Biotechnology*, **24**, 145–149.