

Gamma-ray Energy Spectra Observed around a Nuclear Reactor

NAKASHIMA*, Yoshiyuki, MINATO*, Susumu, KAWANO*, Minoru,

中島敬行 湊進 川野実

TSUJIMOTO**, Tadashi and Kousuke KATSURAYAMA**

辻本忠 桂山幸典

(Received, Oct. 22, 1971)

ABSTRACT

Leakage γ -ray energy spectra up to about 9 MeV were measured by using of a $3''\phi \times 3''L$ NaI (Tl) scintillation counter at two points in the reactor room of KUR (Kyoto University Reactor), and leakage low energy γ -ray (between 10 and 200 keV) spectra were also measured at the reactor power of 5 MW by using of a measuring system which consisted of a $25\text{ mm}\phi \times 2\text{ mm}$ thick NaI (Tl) scintillation counter, a collimator, and a logarithmic amplifier.

Distinct peaks were not found in the observed γ -ray energy spectra up to 9 MeV except O W. In the case of O W, the distributions in the spectra were not found in the energy range above 2.8 MeV.

Peaks at the energies about 200 keV and between 60 and 100 keV were found in many low energy γ -ray spectra. The energy of the former peak corresponds nearly to single back-scattered γ -rays (scattering angle θ , 180°), and the latter one to multiple-scattered. The low energy γ -rays which leaked directly through the shielding wall of the reactor were observed below 30 keV. It was considered that low energy γ -rays leaked through the shielding wall were comparatively weak in intensity, and that high energy γ -rays, when leaked, became to low energy by scattering in the air.

INTRODUCTION

The complete description of a radiation field should include: 1) the types of

* Department of Nuclear Engineering, Faculty of Engineering, Nagoya Univ., Nagoya, Japan.

** Reseach Reactor Institute, Kyoto Univ., Kumatori-cho, Sennan-gun, Osaka, Japan.

radiations, 2) the energy spectrum of each radiation, and 3) the direction of the radiations. However, it seems to be difficult to determine those informations accurately.

The present authors have mainly determined the γ -ray energy spectrum in various fields^{1,2)}. Radioactive nuclides contributed to the spectrum, build-up factors (*e.g.*, number, energy, and dose build-up factors) of the field, and exposure rate could be estimated by determining the energy spectrum of the field.

From the view point of health physics and nuclear engineering, it is considered to be one of the important problems to determine the γ -ray energy spectra observed around a nuclear reactor under operation. Gamma-ray spectra near the reactor core resulting from nuclear fission and thermal-neutron capture by the structural elements were observed by Chapman *et al.*³⁾, in the water shield of the Bulk Shielding Reactor II, and their shapes were rather complicated. As the γ -rays composed of complicated energy spectrum in the core would leak through the reactor shielding and exposure holes of the reactor by scattering or absorption processes, the γ -ray energy spectrum observed around the reactor would be more complicated in shape than those inside the core.

The γ -ray energy spectra around the nuclear reactor (KUR; Kyoto University Reactor) was determined through the measurements of pulse-height distributions and their unfolding by a response matrix. The γ -ray spectra seemed to be not correct at the energy range below several hundred keV because of the attenuation of γ -rays by the housing of a scintillator. As the γ -rays resulting from multiple scattering through the reactor shielding would be dominant, the low energy component of γ -rays would be found to be consist of a continuous spectrum. Low energy γ -ray (between 10 and 200 keV) spectra were determined specially in this study through the measurements of pulse-height distributions due to low energy γ -rays by a thin NaI (Tl) scintillation counter and unfolding by a response matrix.

EXPERIMENTAL AND RESULTS

This experiment was made in the reactor room of KUR. A $3''\phi \times 3''L$ NaI (Tl) scintillation counter was used to measure pulse-height distributions of the γ -ray energy up to about 9 MeV. The obtained distributions were unfolded by use of the inverse matrix of 46×46 and then γ -ray energy spectra were obtained with the aid of an automatic computer.

A $25 \text{ mm}\phi \times 2 \text{ mm}$ thick NaI (Tl) scintillation counter was used to measure pulse-height distributions of γ -rays of the energy between 10 and 200 keV, together with a collimator and a logarithmic amplifier⁴⁾. The lower limit of 10 keV was caused by the noise level of the counter used in the present study. The distributions were also unfolded by iterative method using 30×30 response matrix which was experimentally determined for the measuring system.

Point A was the place where was scarcely affected by the γ -rays arising from radioisotopes placed in the reactor room, because of the added shielding on both

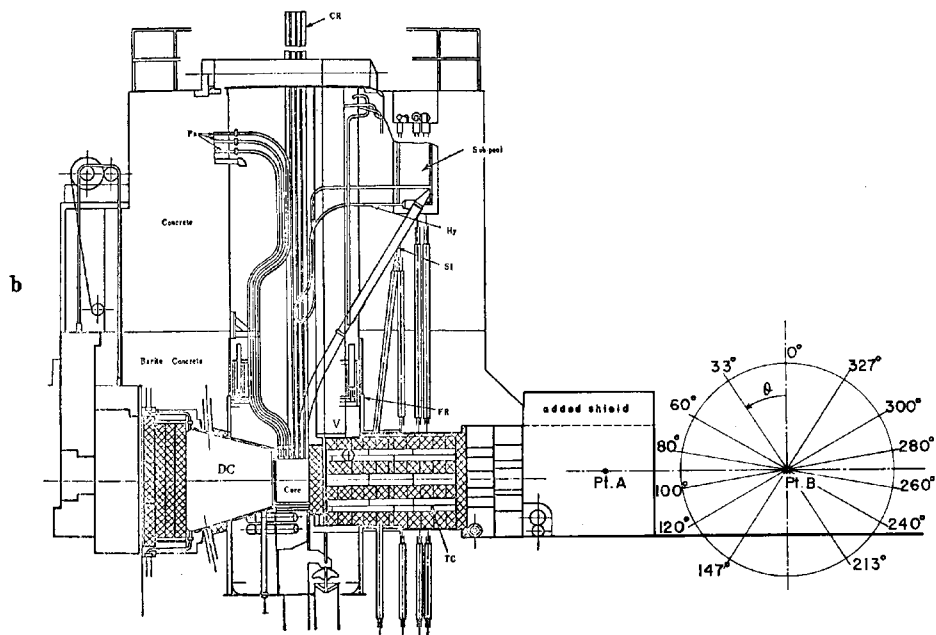
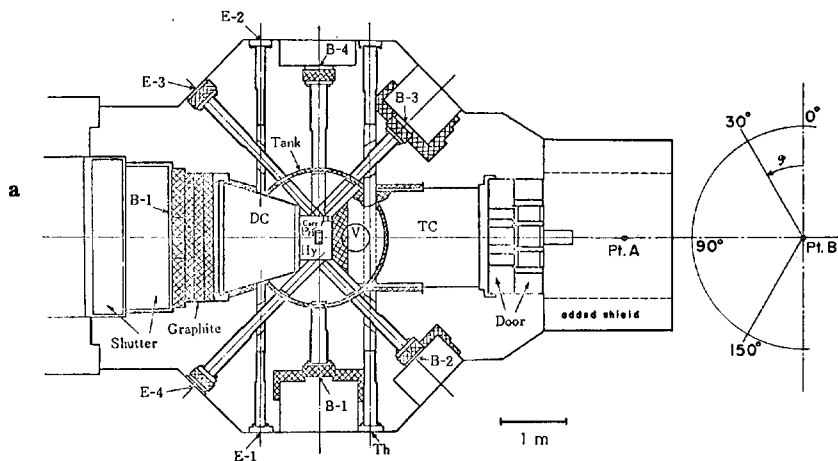

Experimental facilities

- DC Heavy water thermal column
- TC Graphite thermal column
- V Vertical exposure tube (dia. 45 cm)
- B-1~4 Beam hole
 - B-1 Slow chopper
 - B-2 Neutron diffraction
 - B-3 Crystal monochrometer
 - B-4 Mechanical monochrometer

- E-1~4 Horizontal exposure hole
- E-4 Low temperature irradiation loop
- Th Through tube
- Hy Hydraulic exposure tube
- Sl Slant exposure tube
- Pn Pneumatic exposure tube
- CR Control rod
- FR Fuel rack

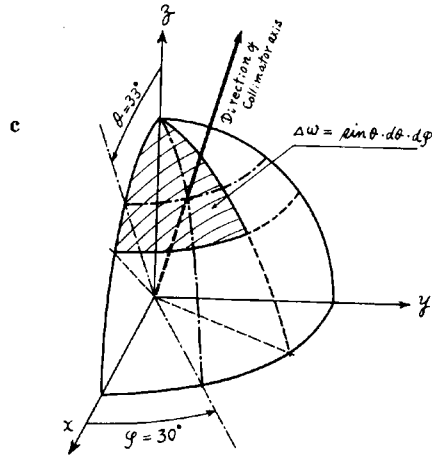

Fig. 1. Plane and cross sectional view of KUR, measuring points (A, and B), and illustrative view of solid angle for the measurement of low energy gamma-ray (between 10 and 200 keV) spectra.

- a plane view of KUR
- b cross sectional view of KUR
- c an example of solid angle

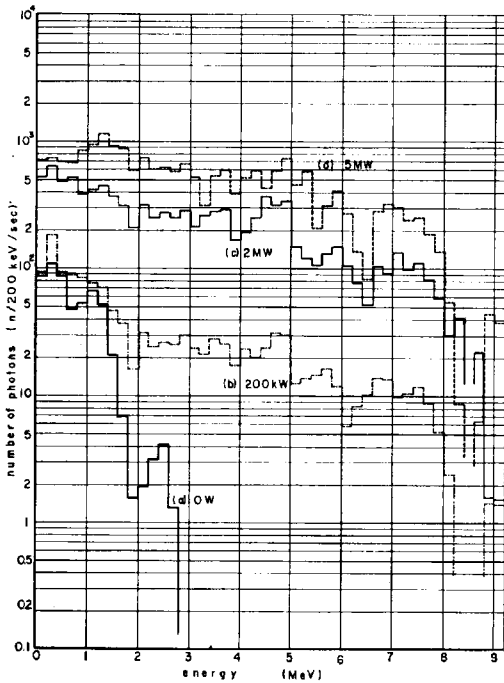

Fig. 2. Incident gamma-ray spectra for various reactor power observed at the Pt. A by 3''φ×3''L NaI (TI) scintillation counter.

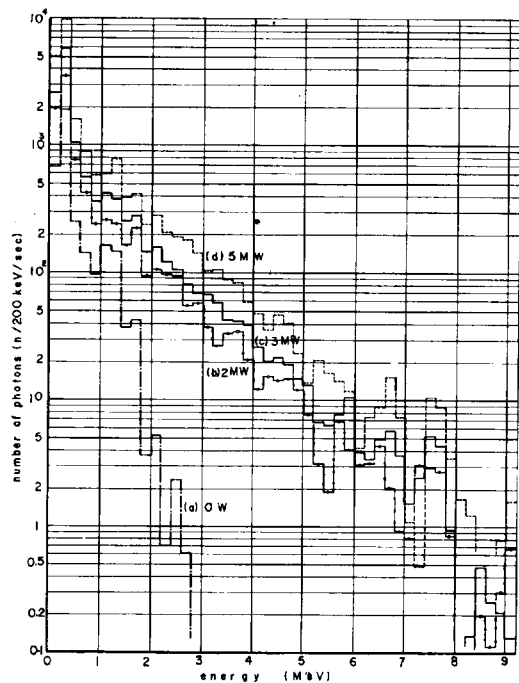

Fig. 3. Incident gamma-ray spectra for various reactor power observed at the Pt. B by 3''φ×3'' LNaI (TI) scintillation counter.

sides and upper side by heavy concrete of 50 cm thick (Fig. 1-a and -b). Therefore, the γ -rays which would be composed of both directly penetrated and scattered through the reactor shielding after originating in the core could be observed. The spectral measurements for the γ -ray energy up to about 9 MeV were made as a function of the reactor power directing the scintillator axis to the reactor core. Results are shown in Fig. 2.

Compared with the point A, the point B was the place where was remarkably affected by γ -rays scattered in the reactor room. The γ -rays observed at the point B would be composed of 1) γ -rays from radioactive sources placed in the reactor room, and their scattered ones, 2) γ -rays from radioactive substances (*e.g.*, radioactive aerosol and gases) in the air, 3) γ -rays penetrated and scattered through the reactor shielding after originating in the core, and their scattered ones in the reactor room, and 4) γ -rays scattered in the reactor room after leakage through the exposure holes of the reactor.

The spectral measurements were made with the $3''\phi \times 3''L$ NaI (Tl) scintillation counter as a function of the reactor power, and with the $25\text{ mm}\phi \times 2\text{ mm}$ thick NaI (Tl) scintillation counter for each combination of (θ_i, φ_j) (*cf.* Fig. 1a and b) only at the reactor power of 5 MW. The space, 4π , for the point B was divided into 36 parts. Fig. 3 shows the γ -ray energy spectra at the point B.

To compare with the γ -ray energy spectra around the reactor, an example of the γ -ray energy spectra in natural environment is shown in Fig. 4 (the width of a histogram was divided in 100 keV).

Fig. 5 shows low energy γ -ray energy spectra for each (θ_i, φ_j) . Fig. 6 shows the low energy γ -ray spectrum from all directions assuming constant flux of low energy γ -rays through the unit area. (*cf.* Fig. 1c).

When the γ -ray spectrum in the field was determined, exposure rate, R_{NaI} ($\mu\text{R}/\text{hr}$), can be calculated by the following equation,

$$R_{\text{NaI}}(\mu\text{R}/\text{hr}) = k \cdot \sum_i N_i \cdot E_i \cdot \mu_a(E_i) \cdot \bar{l} / W_{\text{air}} \cdot V_{\text{NaI}} \cdot t \quad (1)$$

where

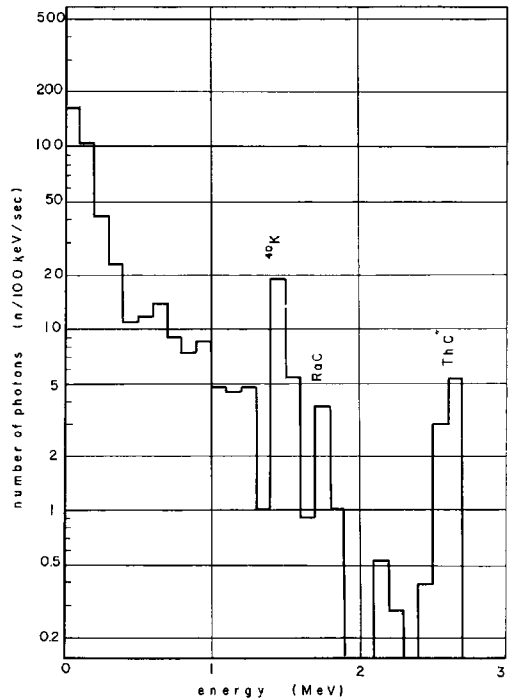

Fig. 4. Incident gamma-ray spectrum in natural environment observed by $3''\phi \times 3''L$ NaI (Tl) scintillation counter.

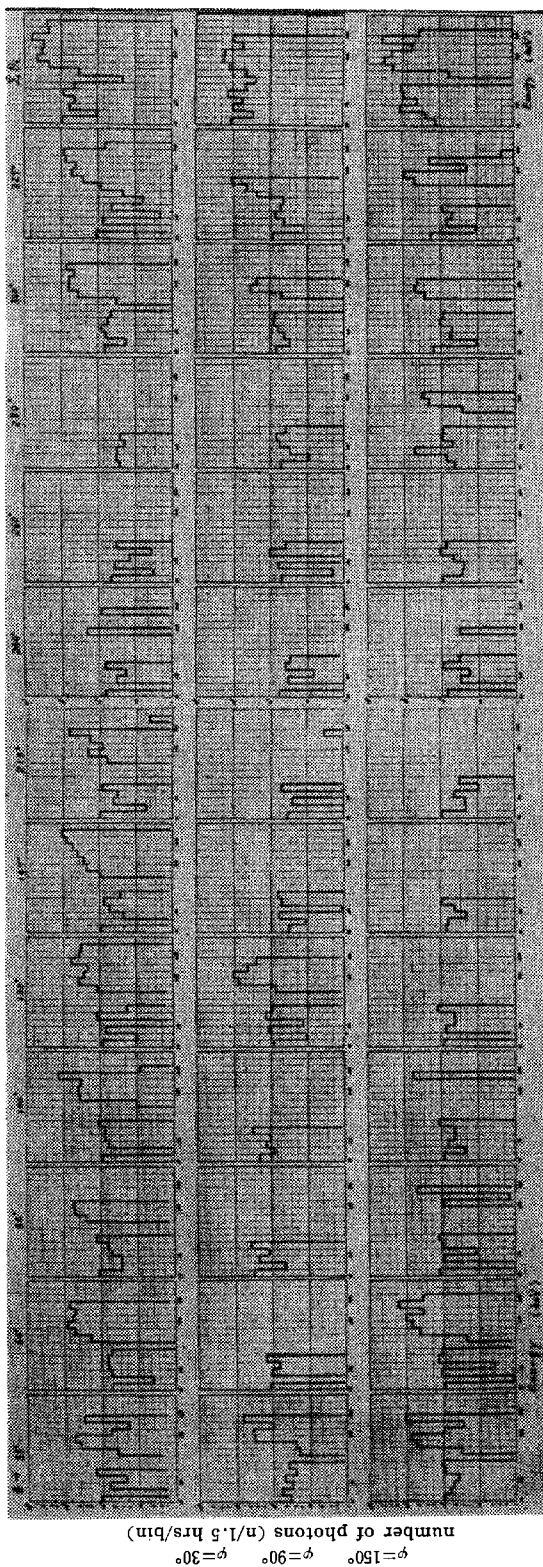

Fig. 5. Low energy gamma-ray spectra for each (θ_i, ϕ_j) .

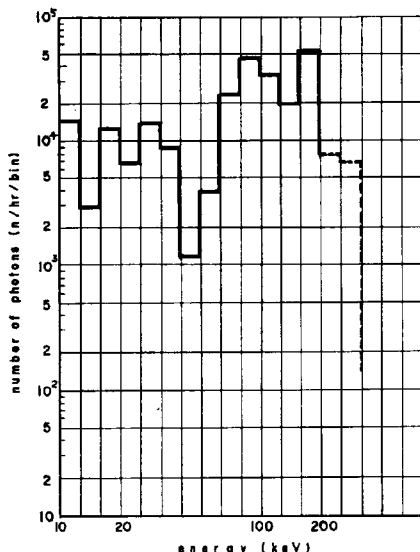

Fig. 6. Low energy gamma-ray (between 10 and 200 keV) spectrum from all directions for the Pt. B.

in the unit path of the air from each histogram shown in Fig. 6.

N_i : number of γ -rays corresponding to the i -th histogram per t sec

E_i : average energy of the i -th histogram (eV)

$\mu_a(E_i)$: energy absorption coefficient of the air for energy E_i (cm^{-1})

\bar{l} : effective length of the scintillator, 5.3 cm in the case of this work, (cm)

V_{NaI} : volume of the scintillator used (cm^3)

W_{air} : average energy dissipated in the air per ion pair formed (eV)

t : measuring time of the spectrum (sec)

k : conversion factor, 1.724.

The relation between exposure rate, R_{NaI} , and that determined by ionization chamber having plastic wall, $R_{\text{i.c.}}$, is shown in Fig. 7.

Exposure rate due to low energy γ -rays (between 10 and 200 keV) was determined to be $35.4 \mu\text{R/hr}$ by calculating energy absorbed

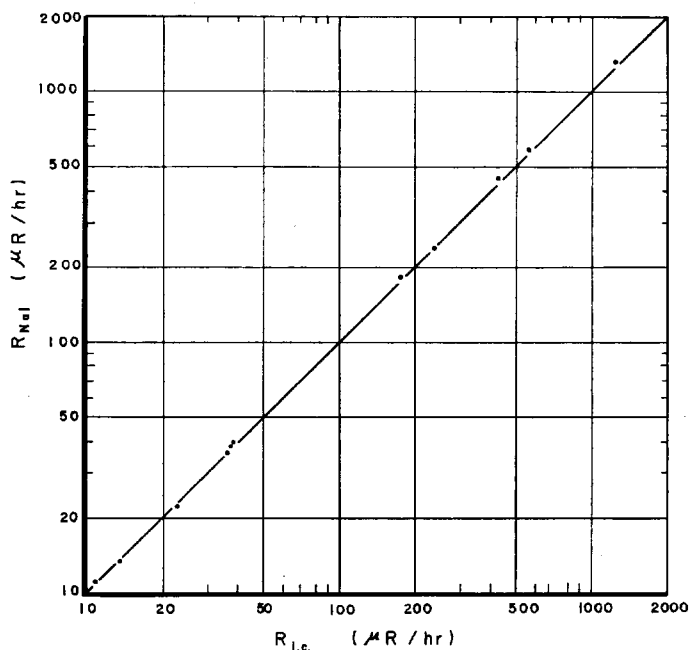

Fig. 7. Relation between R_{NaI} (calculated from the incident gamma-ray spectra) and $R_{\text{i.c.}}$ (observed by the plastic wall ionization chamber).

DISCUSSION

Each spectrum observed at the point A varied their shapes similarly accompanying with reactor power level except that the case of O W. These spectra are almost continuous, and distinct peaks are not found except O W. This seems to be due to poor energy resolution of the scintillation counter, and to γ -rays having very numerous continuous energy. These spectra were composed of γ -rays resulting from forward multiple scattering of γ -rays originated in the reactor core. Pulse-height distribution corresponding to γ -rays above 9 MeV was scarcely observed even for the reactor power 5 MW. On the other hand, the energy distribution above 2.8 MeV could not be observed at O W. The peak at about 2.6 MeV corresponds to γ -rays of ^{208}Tl (ThC''), and this is evident by comparing with the spectrum observed in the natural environment (on the campus of Nagoya University) shown in Fig. 4. The spectrum at O W is probably composed of γ -rays from natural radioisotopes contained in surrounding structural materials and from artificial radioisotopes placed in the reactor room.

As the point B was not surrounded with any shielding material, γ -ray energy spectra observed at this point were considered to be composed of the γ -rays scattered by surrounding material rather than those originated in the reactor core and leaked through the reactor shielding. Numerous increase in the spectra can be found for energies below 5 MeV. The contributions of origins 3) and 4) described in the previous section (§ II) would be comparatively dominant. The spectrum above about 2.8 MeV at O W could not be found as the same of that at A, and the peaks probably due to ^{60}Co γ -rays placed near the point B are shown at the 6-th and 7-th histograms.

Fig. 5 shows the spectra for each (θ_i, φ_j) . As the logarithmic amplifier was used, the energy axis is dividing in log-scale. Therefore, the width of a histogram increases according to energy increase. Following facts are considered by these spectra:

- 1) In the case of $\varphi=90^\circ$, the collimator axis of the measuring system directed to the reactor shielding between $\theta=60^\circ$ and 100° . The distribution above about 30 keV is not found in this case.
- 2) In the case of $\varphi=30^\circ$, the collimator directed to the floor of the reactor room between $\theta=120^\circ$ and 260° . Gamma-rays scattered by the other instrumental arrangements utilizing the exposure hole of the reactor were dominant between $\theta=120^\circ$ and 213° .
- 3) In the case of $\varphi=150^\circ$, the spectra were observed as weak in intensity and low in energy for the collimator axis directed to the floor (between $\theta=120^\circ$ and 260°).
- 4) The spectra of gamma rays could be considerably enhanced both in energy and intensity in the case of the collimator axis directing to upper sides by contrasting Fig. 1. Strong intensity was observed for $\theta=33^\circ, 300^\circ$, and 327° . Consequently, it was considered that low energy γ -rays leaked through the reactor

shielding were comparatively weak in intensity, and that high energy γ -rays, when leaked, became to low energy by scattering in the air.

- 5) Peaks can be seen in both about 200 keV and between 60 and 100 keV in many spectra in Fig. 5. The energy of the former peak corresponds nearly to single back-scattered γ -rays (scattering angle $\theta \approx 180^\circ$), and the latter one to multiple-scattered.

The corrected low energy spectrum incident on the point B from all directions shows the evident peaks at 200 keV and between 60 and 100 keV.

Exposure rate, R_{NaI} , calculated by equation (1) coincides fairly well with that measured by using the ionization chamber of 15 l sensitive volume as shown in Fig. 7. R_{NaI} is slightly larger than $R_{\text{i.c.}}$ under the irradiated condition of high exposure rate.

CONCLUSION

Distinct peaks were not found in the γ -ray energy spectra for the energy up to about 9 MeV around the nuclear reactor. They were almost continuous spectrum.

Low energy γ -ray spectra showed the distinct peaks of the energies at around 200 keV and between 60 and 100 keV. The former peak corresponded to the energy of back-scattered γ -rays and the latter one to the energy of multiple-scattered γ -rays in back-scattering experiment. Energy of directly leaked γ -rays through the reactor shielding was below about 30 keV.

This method described in this paper would be useful as one of the measurements in the field of health physics.

BRIEF DESCRIPTION OF KUR

KUR is a light-water-moderated research reactor using 90 per cent enriched uranium fuel. Its nominal power is 5 MW. The construction of the core is almost similar to Bulk Shield Reactor (BSR) at Oak Ridge National Laboratory, USA. The core KUR is housed in an aluminium tank 2 meters in diameter. The core of KUR comprises the MTR type fuel elements, consisting of 18 fuel plates made of aluminium alloy with aluminium cladding. The mass of U-235 contained in each fuel element is about 165 grams, and the critical mass is about 3 kilograms of U-235 or slightly less than 20 fuel elements at clean and cold conditions. In practice, however, 5 special fuel elements, into which the control rod is inserted, are used, and, moreover, about three fuel elements are generally loaded in order to give an excess reactivity up-to 4.5 per cent $\Delta K/K$ at the maximum. Around those fuel elements, graphite reflector elements are placed. The other constructions are given in Fig. 1a and b).

REFERENCES

1. Minato, S. and M. Kawano (1970) On the constitution of terrestrial gamma radiation. *J. Geophys. Res.*, **75**, 5825-5830.
2. Nakashima, Y., Minato, S., Kawano, M., Tsujimoto, T. and K. Katsurayama (1970) Leakage γ -ray spectra around KUR during period of power increase. *J. Atomic Energy Soc. Japan*, **12**, 577-581.
3. Chapman, G. T. and W. R. Burrus (1968) Spectrum of gamma rays emitted by a stainless

steel clad, pool-type reactor (BSR-II). *Nucl. Sci. Eng.*, **34**, 169-180.

4. Nakashima, Y., Minato, S., Kawano, M., Tsujimoto, T. and K. Katsurayama (1972) Unfolding of pulse-height distribution due to low energy γ -ray. to be published in *J. Atomic Energy Soc. Japan*.